

Sine Filters

10-410A SERIES, TYPE SINE

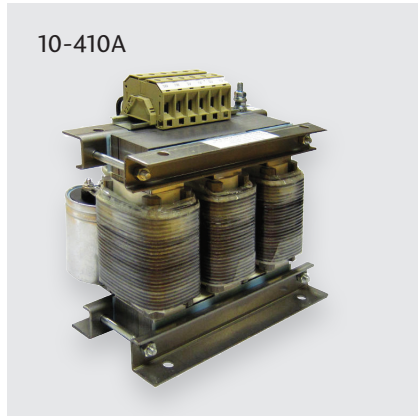

10-410A

FILTER SERIES FOR PROTECTING THE MOTORS

- Eliminates the additional voltage stress from the drive output voltage
- Increases the lifetime of the motor
- Sine filters reduce the insulation stress of the motors by filtering the output voltage of the variable speed drive. The reduced stress increases the lifetime of motor windings.
- Sine filters can be used with cable lengths longer than dU/dt- filters. Sine filters are designed for a switching frequency of 1,5 - 4,0 KHz.
- Sine filters can also be used in retrofit applications, where the motor is not designed for use with a variable speed drive

Connection diagram

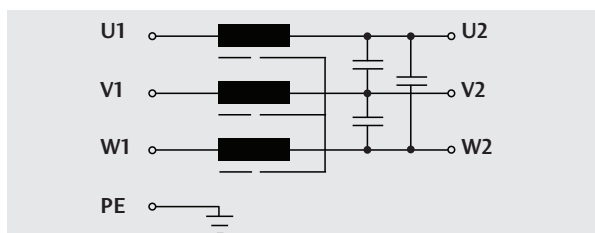

Technical specifications

Standards	UL/Ur, RoHs, CE	Max. cable length	No limit
Design	Open frame design	Voltage loss	ap 6 % at nominal current
Operating voltage range	380...500 V ±10%	Ambient temperature	40 °C in operation
Motor current frequency	0-70 Hz	Moisture	< 95 % RH, no condensation
Switching frequency	380 - 500 V 1,5 - 4,0 kHz	Protection class	IP00
Max remaining voltage ripple	40 V p-p	Materials	UL-listed

The waveform of the inverter voltage without sine filter.

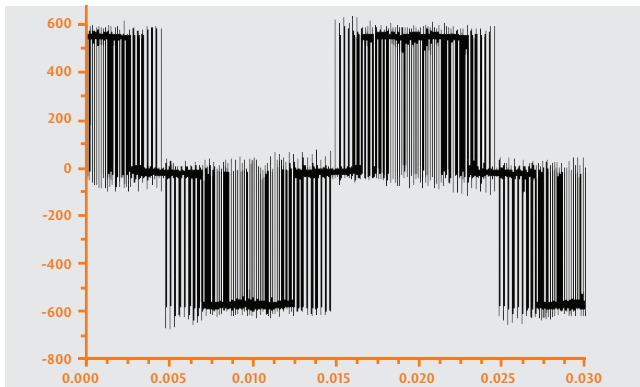

The waveform of the motor voltage with sine filter.

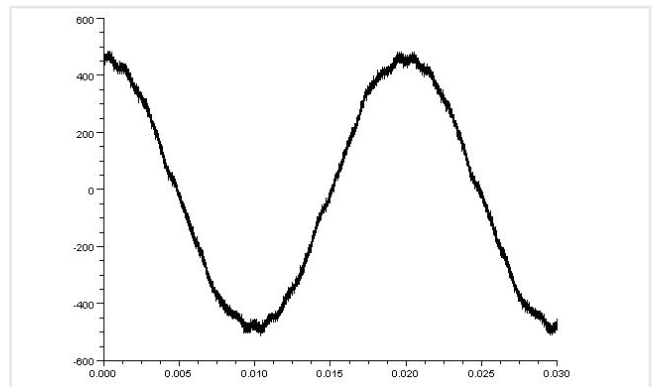

The waveform of the motor current with sine filter.

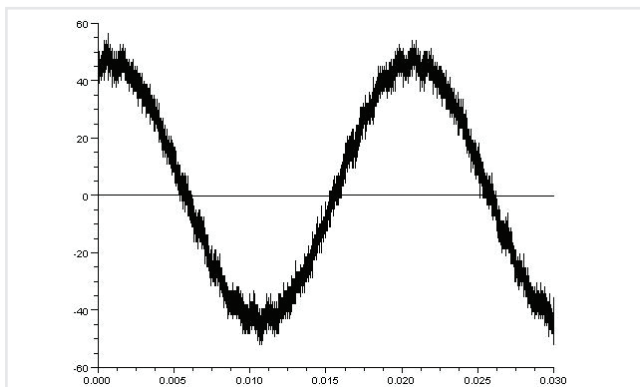

Mechanical data 10A - 410A

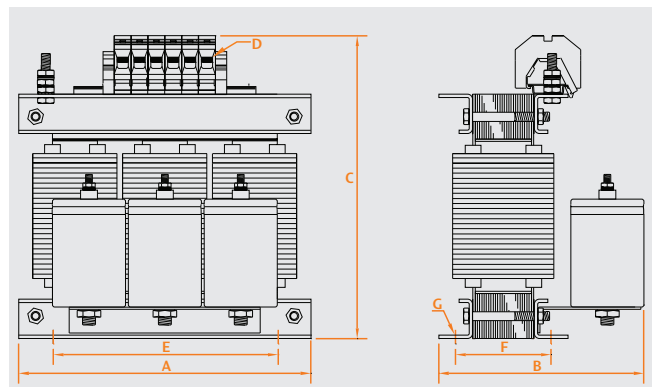

Order code	Rated current [A]	A [mm]	B [mm]	C [mm]	D [mm ²]	E [mm]	F [mm]	G [mm]	Weight [kg]	Losses [W]
SINE10	10	178	125	188	10 mm ²	125	70	8x15	6,40	70
SINE18	18	225	165	250	10 mm ²	175	75	10x13	13,00	135
SINE32	32	260	183	270	35 mm ²	200	85	Ø10	20,10	195
SINE48	48	260	205	260	35 mm ²	200	109	10x13	25,00	255
SINE75	75	350	350	292	Ø9 mm	250	125	11x20	42,00	330
SINE110	110	380	350	318	Ø11 mm	250	126	11x20	66,00	390
SINE180	180	450	375	360	Ø11 mm	300	140	11x20	94,20	500
SINE270	270	495	430	435	-	465	160	11x20	134,30	640
SINE410	410	495	464	496	Ø18 mm	465	200	11x20	188,00	880
SINE460	460	495	470	505	-	465	200	11x20	200,70	

Muuntosähkö

Trafox is a brand of Muuntosähkö Oy. We develop, manufacture and customise high-quality transformers, chokes, filters and Trafox Superintend® monitoring devices for a large number of applications.

MUUNTOSÄHKÖ OY TRAFIX

P.O. Box 10 | FI-00621 Helsinki | Tel. +358 207 933 700 | Fax +358 207 933 746 | sales@trafox.fi



www.trafox.fi